

F. M. CALER.
WOOD WORKING MACHINE.

No. 361,261.

Patented Apr. 19, 1887.

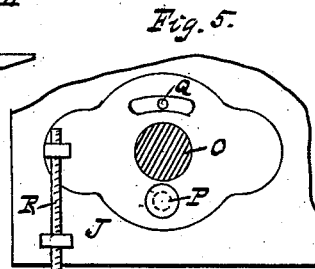
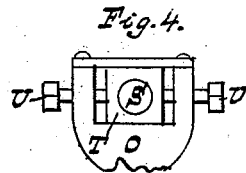
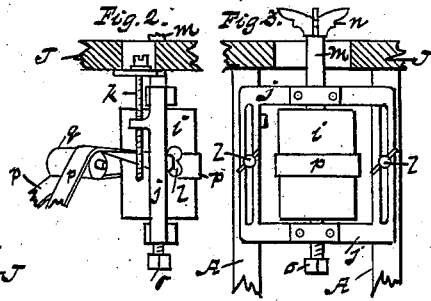
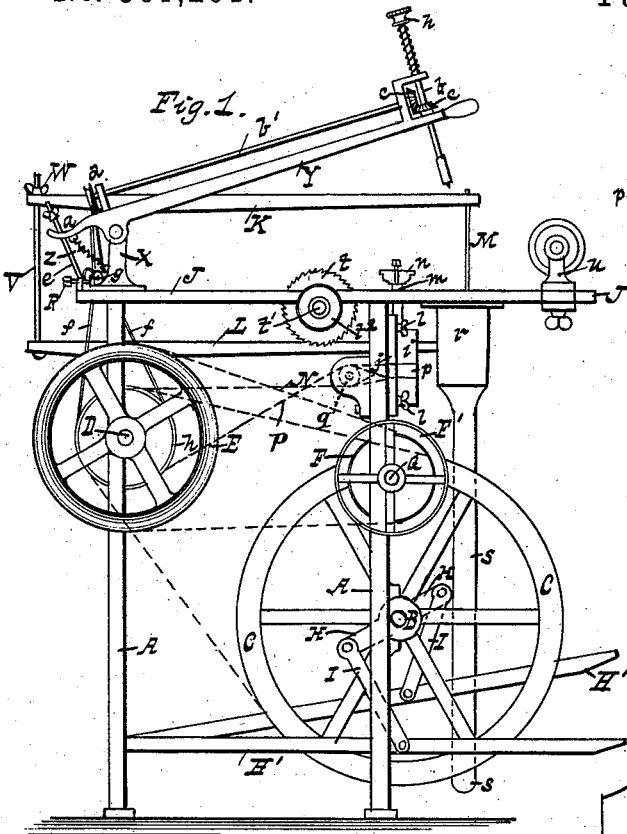

Fig. 6.

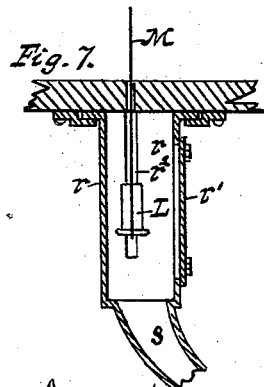
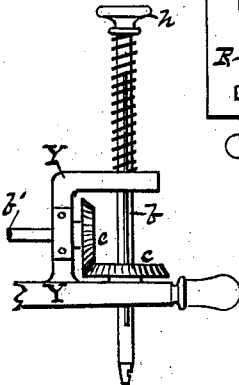
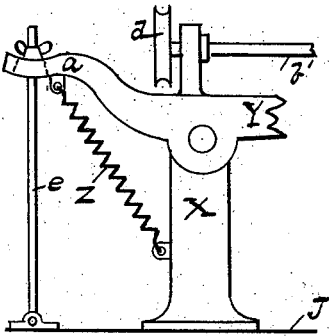
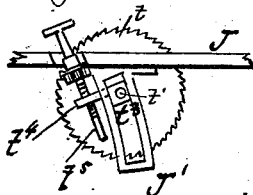

Fig. 8.



ATTORNEYS:
Joseph W. Ellis
W. E. Harrison.

Inventor,
Francis M. Caler
 BY *C. D. Lewis*
 Atty. y.

(No Model.)

2 Sheets—Sheet 2.

F. M. CALER.
WOOD WORKING MACHINE.

No. 361,261

Patented Apr. 19, 1887.

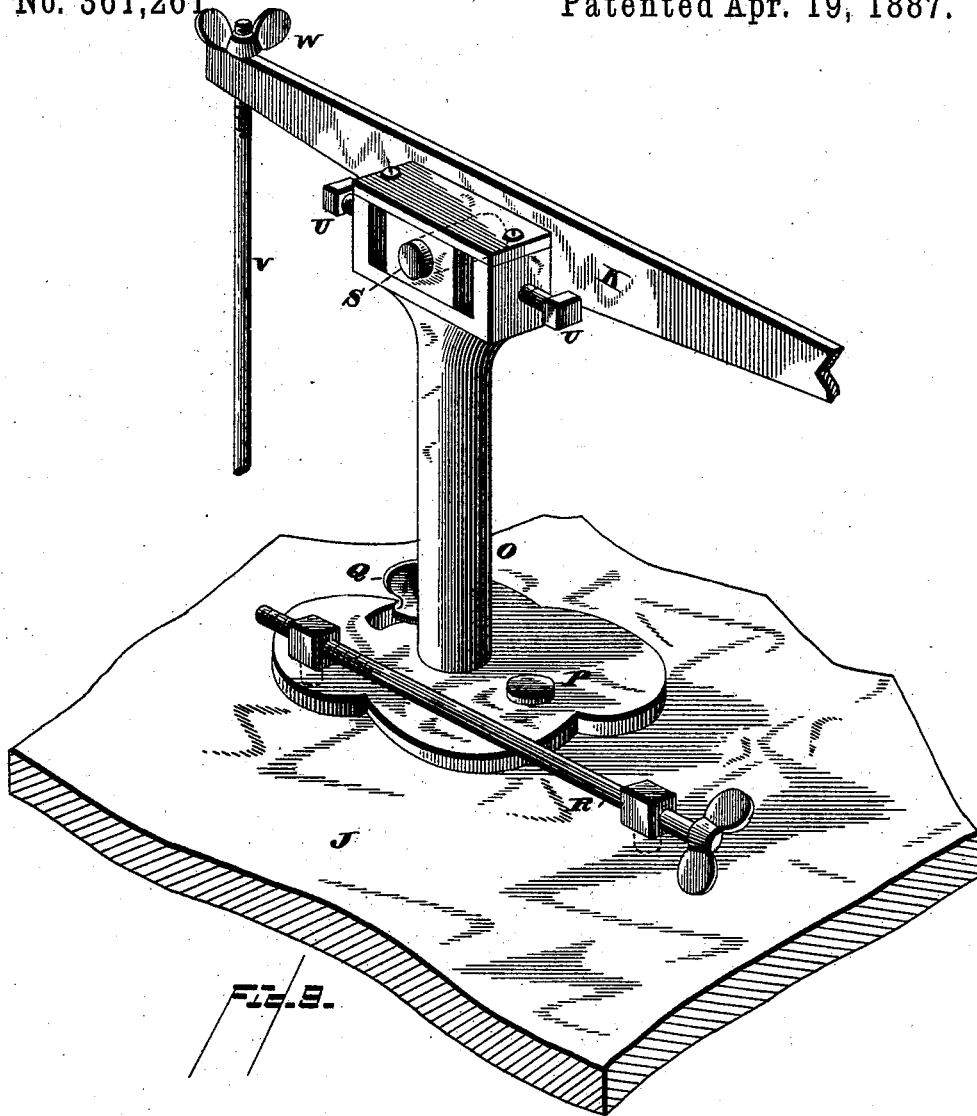

Witnesses:

W. H. Washburn
James J. Sheehy

Inventor:

F. M. Caler.
By, O. D. Lewis
his
Attorneys.

UNITED STATES PATENT OFFICE.

FRANCIS M. CALER, OF PITTSBURG, PENNSYLVANIA.

WOOD-WORKING MACHINE.

SPECIFICATION forming part of Letters Patent No. 361,261, dated April 19, 1887.

Application filed March 4, 1886. Serial No. 194,074. (No model.)

To all whom it may concern:

Be it known that I, FRANCIS M. CALER, a citizen of the United States, residing at Pittsburg, in the county of Allegheny and State of Pennsylvania, have invented certain new and useful Improvements in a Combined Wood-Working Machine; and I do hereby declare the following to be a full, clear, and exact description of the invention, such as will enable others skilled in the art to which it pertains to make and use the same, reference being had to the accompanying drawings, which form a part of this specification.

My invention relates to an improvement in wood-working machines, the object being to provide a machine of simple and durable construction that will take the place of several separate and distinct machines; and with this end in view my invention consists in certain details of construction and combination of parts, as will be hereinafter more fully set forth.

In the accompanying drawings, Figure 1 is a side elevation of my improved wood-working machine, showing relative positions of the several peculiar devices comprising my invention. Fig. 2 is an edge or end elevation of the adjustable pulley used in connection with the wood-molding device. Fig. 3 is a side elevation of the same, showing the shaping-tool in position. Fig. 4 is a side view of one of the bearings used in suspending the top horizontal saw-bar, showing a means for adjusting the same. Fig. 5 is a plan view of the base of the adjustable bearing. Fig. 6 is a side elevation of the boring device. Fig. 7 is a sectional elevation of the trough and box to conduct the sawdust to any desired point. Fig. 8 is a side view of the device for raising or lowering the saw above or below the table by means of a wrench, sliding block, and screw. Fig. 9 is a perspective view in detail of the scroll-saw-supporting device on top of the table.

To put my invention into practice, I provide a frame, A, of suitable size and form of construction, across the front of which I place a shaft, B, mounted in suitable bearings. To this shaft B is attached a large wheel, C, which answers the double purpose of fly-wheel and pulley. Across the rear of the frame A, I

place in proper bearings a shaft, D, parallel to that before described. Securely attached to this shaft D are a number of large and small pulleys, one of which, E, transmits motion to a pulley, F, secured to a shaft, G, at the front of the machine. To each end of the shaft B is affixed a crank, H, connected to treadles H' by short bars I.

On the top of the frame A is placed a broad flat table, J, upon which the operator works. At the rear of this table J is rigidly secured the main support of the saw-frame K L, which usually consists of two tough and slightly-elastic wooden arms arranged in a perpendicular line one over the other, and reaching, respectively, over and under the table J, where they carry the jig-saw M, which passes through a slot in the table J, and is connected at opposite ends to the respective saw-frame arms K L by the ordinary and well-known means, not requiring a detailed description in this case. The lower arm, L, being connected with a crank on the shaft G by a short pitman, and said shaft being rotated by the driving-belt N, imparts the vibratory motion to the saw-frame K L and the reciprocating motion to the saw M. The main support O of the saw-frame K L is in the form of a post, which is attached to the table J by a bolt, P, and thumb-screw Q. This post O may be revolved by means of the screw R, and thereby adjust the saw-frame K L to conform to the opening in the table J.

The pivot or shaft S, supporting the upper bar, K, of the saw-frame, is placed in a square bushing, T, and held in position by set-screws U, (see Fig. 4,) and the bar K may be adjusted sidewise by releasing one set-screw and tightening the other. A strain-rod, V, extends through the two saw-frames K L, back of the post O, and provided at one or both ends with a nut, W, or nuts, by which to exert the requisite pressure on the rear ends of the arms K L to cause the forward ends thereof to hold the saw M at the desired tension.

Secured to the table J, at the rear, is a vertical post, X, carrying an arm, Y, to which is attached a boring device. A spring, Z, secured to the one end *a* of this arm Y, and to the vertical post X, holds the arm in an inclined position when not in use. To the forward end of the arm Y is loosely attached a

boring-tool, *b*, which is operated by small beveled gearing *c*, driven by a grooved pulley, *d*, situated at the rear of the arm Y. A hinged adjustable bolt, *e*, is secured through a slot to the rear of the arm Y, and serves to stop the tool *b* when in a perpendicular position, or at an angle with the table J, if so desired. The pulley *d* is rotated by a driving-belt, *f*, guided by idlers *g* from a large pulley, E, placed on the shaft D, secured to the frame A. When desired to use the boring-tool *b*, the arm Y is pressed down until stopped by the bolt *e* at the rear. The operator, pressing the knob *h*, brings the tool *b* in contact with the work. The driving-belt *f* is tightened by the movement of the arm Y.

Secured to the front of the frame A, and placed beneath the table J, is a vertical pulley, *i*, placed in a frame, *j*, capable of a limited vertical movement by means of a threaded rod, K, secured to the table J and the rear of the pulley-frame *i*, and held in any position by set-screws *l*. To the top of the shaft *m*, to which the pulley *i* is secured, is placed a molding-tool, *n*, extending a short distance above the surface of the table J. The lost motion of the pulley *i* may be taken up by a set-screw, *o*, placed at the base of the same. A driving-belt, *p*, placed over suitable guides, *g*, and about a pulley on the shaft D, rotates the same.

The lower portion of the saw M is inclosed in a box, *r*, having a sliding door, *r'*, at the front, through which the saw M may be secured to the frame L or detached therefrom. A vertical slot, *r''*, at the rear of the box *r* allows the saw-frame L free motion. From the base of the box *r* is conducted a tube or trough, *s*, to any convenient place, through which the sawdust may pass and not interfere with the operator.

Near the middle of the table J is placed a circular saw, *t*, mounted on a shaft, *t'*, to one end of which is attached a pulley, *t''*, which may be rotated by a driving-belt from the pulley F'. The shaft *t'* has its bearing in a block, *t'''*, guided by a slotted segmental bracket, J', rigidly secured to the bottom of the table J, and said block *t'''* is provided with a screw-tapped extension, *t''''*, through which passes a screw, *t'''''*, having a hand or wrench-head on its upper end. The saw *t* can thus be adjusted vertically.

To the front of the table J a small lathe, *u*, may be attached, and readily removed when not in use. The same pulley, F', for operating the circular saw *t*, may be used in connection with the lathe *u*.

Having thus described my invention, what I claim, and desire to secure by Letters Patent, is—

1. In a combined wood-working machine, the combination, with the main frame, its working-table, and the shafts bearing belt-pulleys actuated by treadle mechanism, of the main saw-support O, located on top of and near the rear end of the table J, supported by an axially-adjustable base, the pivot P, the thumb-screw Q and its slot, the adjusting-screw R, and a laterally-adjustable bearing-block for the shaft S, which supports the saw-frame, which shaft receives motion from shaft D, all as described.

2. The combination of the vibrating arm Y, the standard bearing the axis of this arm located at the rear part of the table J and one side of the plane of the saw-frame support, a spring-actuated rotative boring-tool on the front end of said arm, the bevel gear-wheels C C, the pulley *d* on the shaft of one of these wheels, receiving rotation from the shaft D, the pivoted rod *e* and its adjusting-nut connecting the table J and the short curved end of the arm Y, for adjusting the degree of depression of this arm, and a spring, Z, for raising this arm, all substantially as described.

3. In a combined wood-working machine, the combination, with the main frame and its table and the two shafts B D, their belt-pulleys and treadle mechanism, of a saw-frame axially adjustable by means of a pivot, P, a set-screw, Q, and an adjusting-screw, R, laterally adjustable by means of a journal-block and its set-screws on the upper end of the standard O, the guide and conducting-off tube with the plate *r'*, removable, as described, a circular saw receiving rotation from the shaft D and journaled in a block in a curved bracket concentric to the axis of said shaft D, from which it receives rotation, the adjusting-screw *t''*, applied to an extension of said block, the vibrating spring-actuated arm Y, arranged alongside of the said saw-frame and supported near the rear end of the table J, and bearing a rotative spring-actuated boring-tool, also receiving motion from said shaft D, and a molding-tool arranged in advance of the circular saw and in rear but to one side of the straight saw M, substantially as described.

FRANCIS M. CALER.

Witnesses:

H. T. MORRIS,
M. E. HARRISON.